

Figure 4 - The administration part

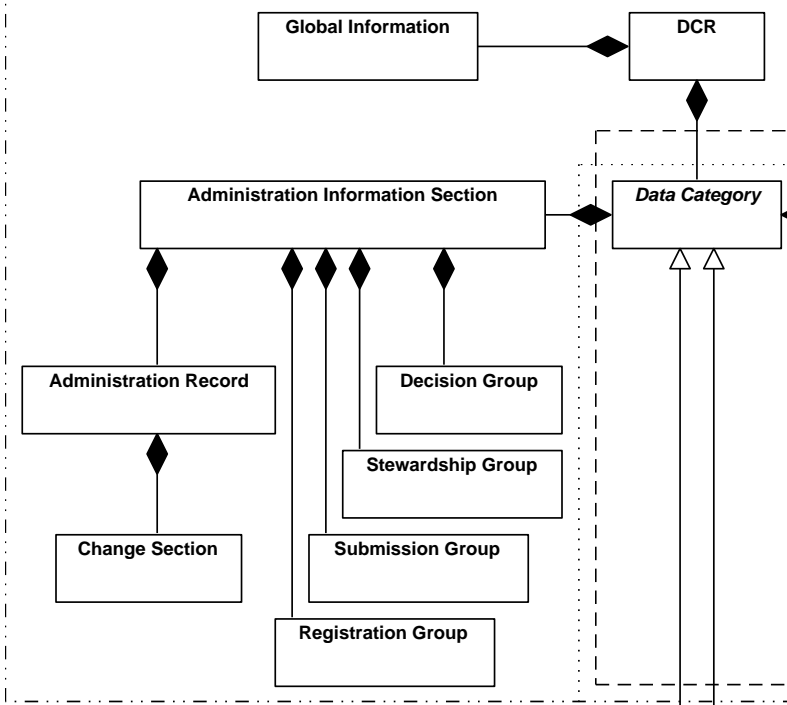

Figure 5 - The description part

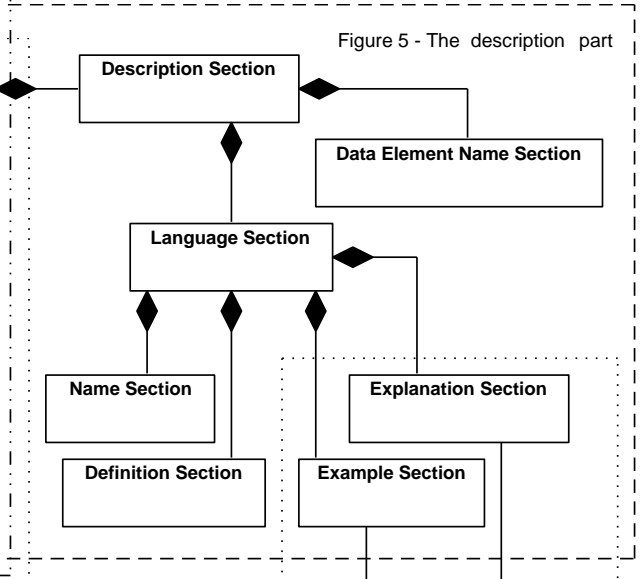
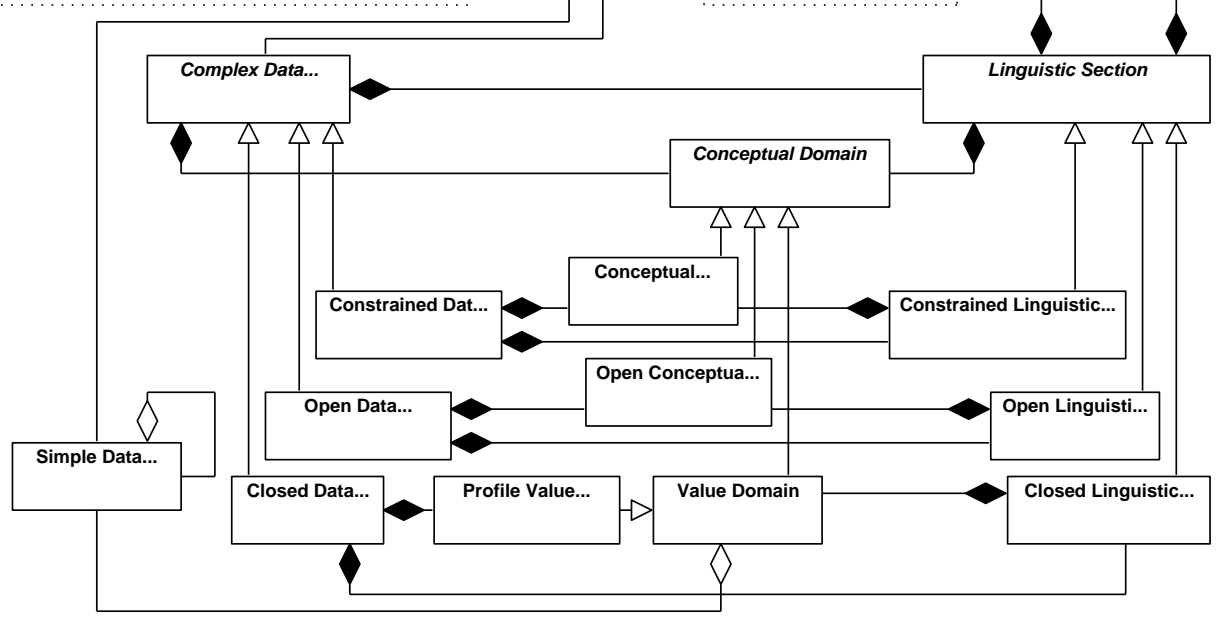
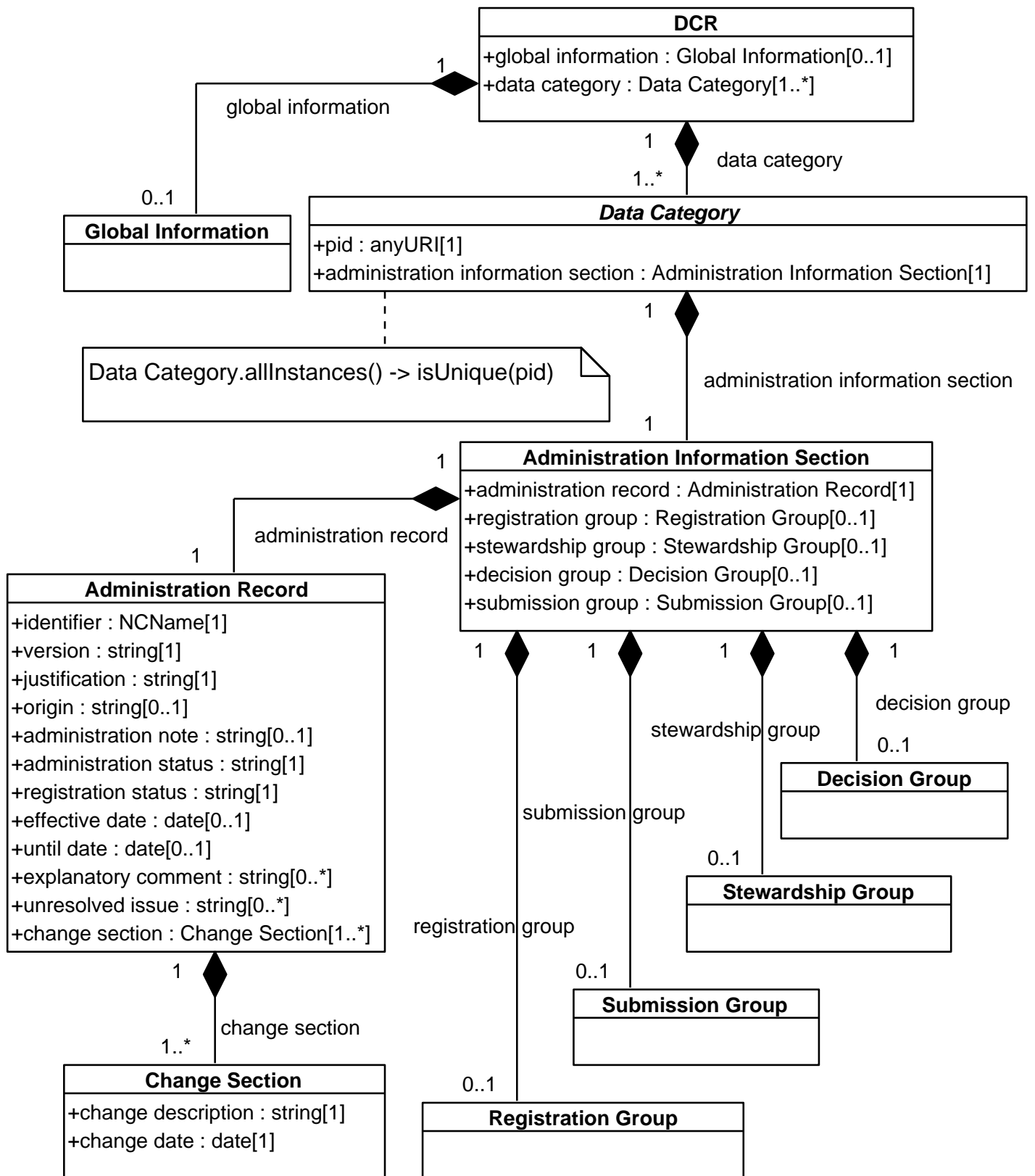

Figure 6 - The linguistic part





self.language section -> isUnique(language) and
 self.language section -> one(language = 'en' and definition section -> notEmpty() and name section -> notEmpty())

